

## Positioning Sensors · pneumatical

22800.0020



### Product Description

Used in jigs and fixtures as positioning control for pre-machined workpieces. Sensitivity accuracy is 0.015-0.075 mm, depending on the workpiece surface. Contact control is achieved through compressed air backwash and is indicated on the monitoring unit.

### Material

#### Seating Pins

- Tool steel, hardened, ground

#### Seal

- PVC

#### Screw

- Steel, zinc-plated by galvanization, quality 4.8 (ISO 1207)

#### Plug-in nipple

- Brass

### More information

#### Notes

Further information on request.

#### Further products

- Monitoring Units, for positioning sensors, pneumatic

### Drawing

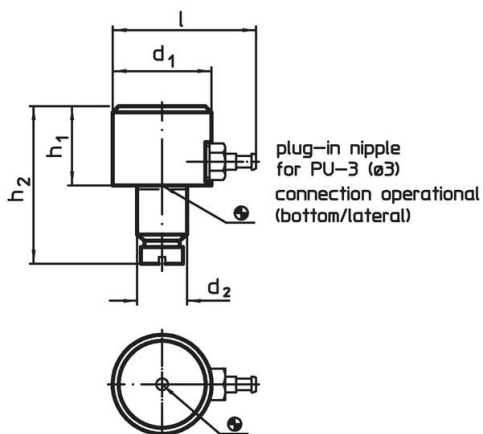

picture 1

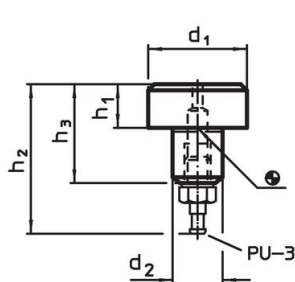

picture 2

### Order information

Dimensions					[g]	Art. No.
d <sub>1</sub>	h <sub>1</sub> h <sub>9</sub>	d <sub>2</sub> n6 [mm]	h <sub>2</sub>	l		
bottom/lateral connection – picture 1						
25	20	12	39	36.5	93	22800.0020

## Application example

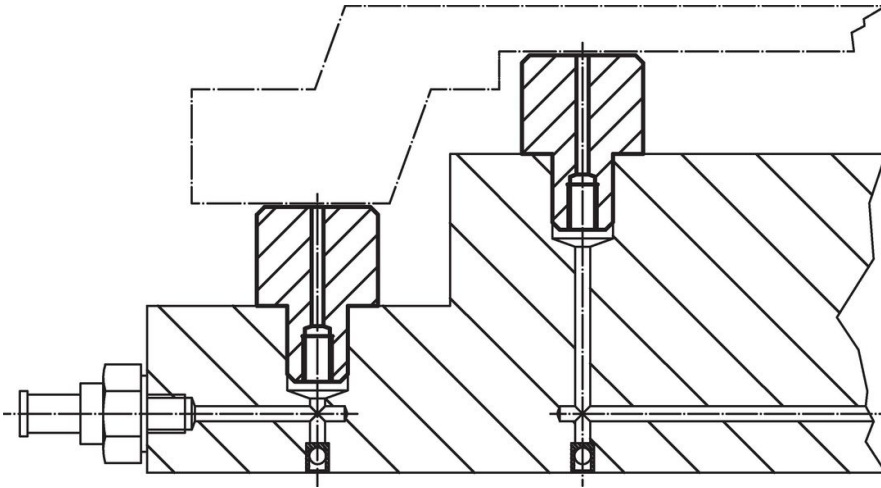

## Compliance

### RoHS compliant

Compliant according to Directive 2011/65/EU and Directive 2015/863.

### Does not contain SVHC substances

No SVHC substances with more than 0.1% w/w contained - SVHC list [REACH] as of 27.06.2024.

### Does not contain Proposition 65 substances

No Proposition 65 substances included.

<https://www.P65Warnings.ca.gov/>

### Free from Conflict Minerals

This product does not contain any substances designated as "conflict minerals" such as tantalum, tin, gold or tungsten from the Democratic Republic of Congo or adjacent countries.