

## Eccentric Clamps

23271.0010



### Product Description

The eccentric clamp allows clamping with pull-down effect on different workpiece forms at low height.

### Material

- Case-hardened steel, case-hardened and blue zinc-plated

### Assembly

1. Manufacture a thread with the corresponding distance  $L_2 / L_3$  to the workpiece.
2. Screw in the eccentric clamp at the necessary height and set it relative to the workpiece with its flat side.
3. Insert the workpiece and tighten the clamping pin using the internal hexagon. The proper tension is achieved after approx. 1/3 turn.

The threaded hole must be lubricated on a regular basis.

The rotational movement during tightening must always be completed towards the stops in order to prevent the workpiece from turning away from the stops.

### Drawing

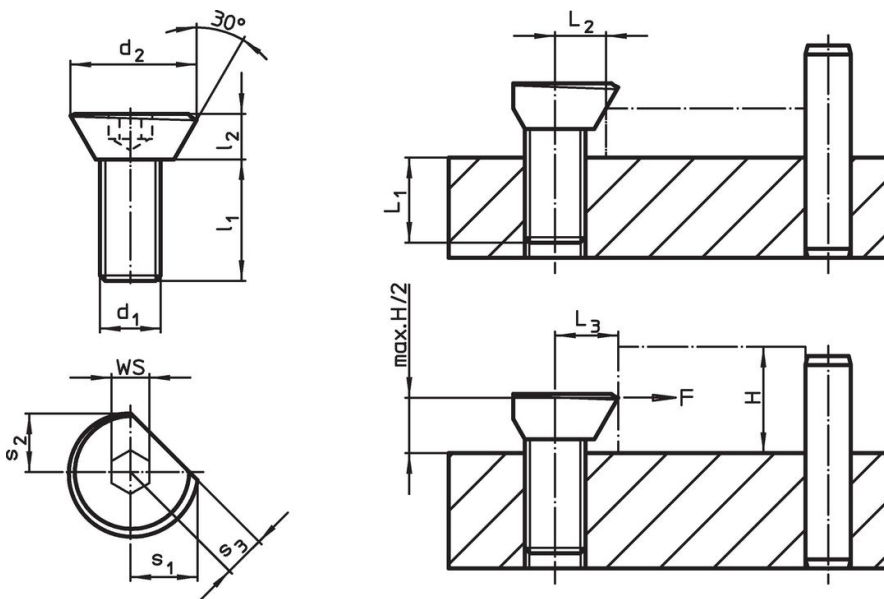

### Order information

Dimensions							$L_1$	$L_2$	$L_3$	WS	Clamping force max.	Tightening torque max.	Art. No.	
$d_1$	$d_2$	$l_1$	$l_2$	$s_1$	$s_2$	$s_3$	[mm]	[mm]	$\pm 0.2$	[mm]	[kN]	[Nm]		[g]
[mm]							[mm]	[mm]	[mm]	[mm]				
M10	20.9	20	7	11.1	9.4	6.5	10	8.3	9.8	6	4	30	20	23271.0010

### Application example



### Compliance

Contains lead - compliant according to exceptions 6a / 6b / 6c.

Contains SVHC substances >0,1% w/w

Contains lead - SVHC list [REACH] as of 27.06.2024.

Contains Proposition 65 substances



Lead can cause cancer and reproductive harm from exposure  
<https://www.P65Warnings.ca.gov/>